

Concurrent Execution

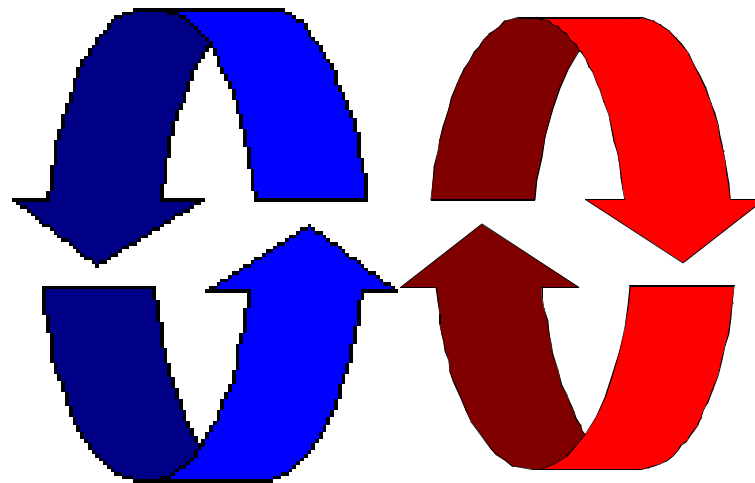

Concurrent execution

Concepts: processes - concurrent execution
and interleaving.
process interaction.

Models: **parallel composition** of asynchronous processes
- interleaving
interaction - shared actions
process labeling, and action relabeling and hiding
structure diagrams

Practice: Multithreaded Java programs

Definitions

◆ *Concurrency*

- *Logically* simultaneous processing. Does not imply multiple processing elements (PEs). Requires interleaved execution on a single PE.

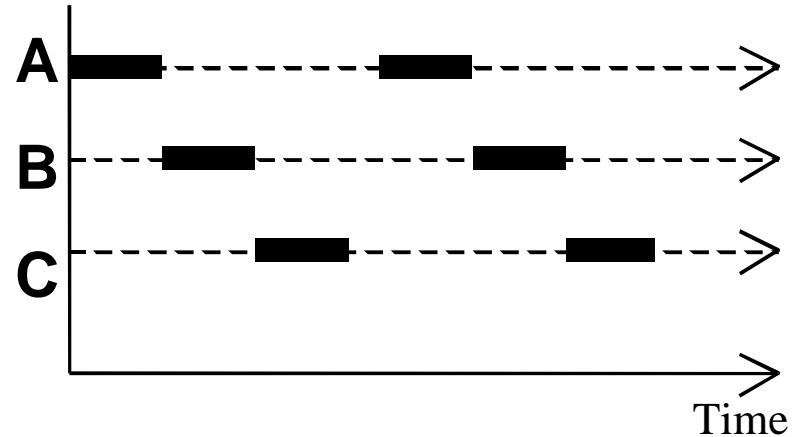

◆ *Parallelism*

- *Physically* simultaneous processing. Involves multiple PEs and/or independent device operations.

Both concurrency and parallelism require controlled access to shared resources . We use the terms parallel and concurrent interchangeably and generally do not distinguish between real and pseudo-concurrent execution.

3.1 Modeling Concurrency

- ◆ How should we model process execution speed?
 - arbitrary speed
(we abstract away time)
- ◆ How do we model concurrency?
 - arbitrary relative order of actions from different processes
(**interleaving** but preservation of each process order)
- ◆ What is the result?
 - provides a general model independent of scheduling
(**asynchronous** model of execution)

parallel composition - action interleaving

If P and Q are processes then $(P||Q)$ represents the concurrent execution of P and Q . The operator $||$ is the parallel composition operator.

```
ITCH = (scratch->STOP) .
```

```
CONVERSE = (think->talk->STOP) .
```

```
|| CONVERSE_ITCH = (ITCH || CONVERSE) .
```

```
think→talk→scratch
```

```
think→scratch→talk
```

```
scratch→think→talk
```

Possible traces as
a result of action
interleaving.

parallel composition - action interleaving

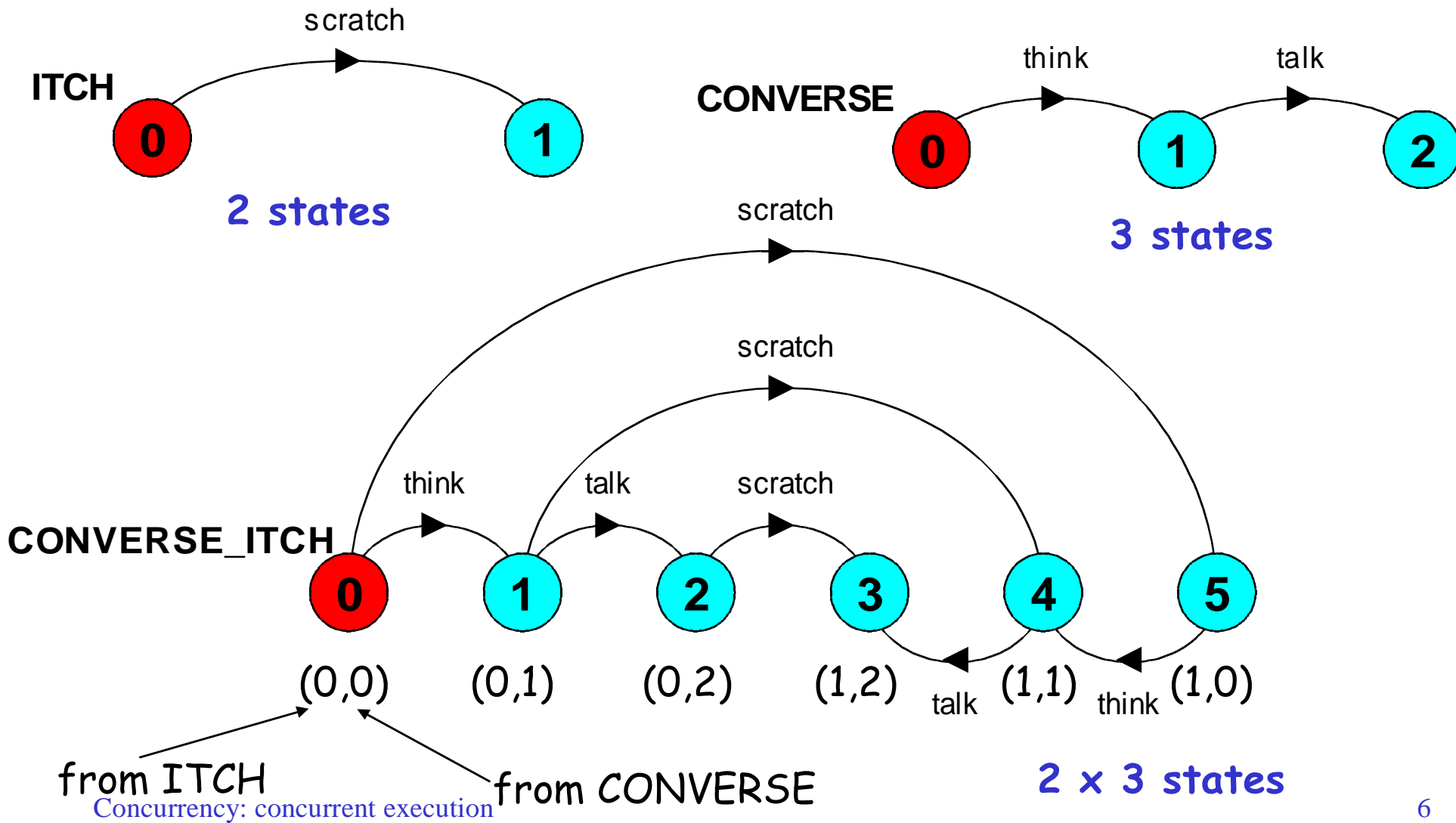

parallel composition - algebraic laws

Commutative: $(P \parallel Q) = (Q \parallel P)$

Associative: $(P \parallel (Q \parallel R)) = ((P \parallel Q) \parallel R)$
 $= (P \parallel Q \parallel R) .$

Clock radio example:

`CLOCK = (tick->CLOCK) .`

`RADIO = (on->off->RADIO) .`

`|| CLOCK_RADIO = (CLOCK || RADIO) .`

LTS? Traces? Number of states?

modeling interaction - shared actions

If processes in a composition have actions in common, these actions are said to be *shared*. Shared actions are the way that process interaction is modeled. While unshared actions may be arbitrarily interleaved, a shared action must be executed at the same time by all processes that participate in the shared action.

```
MAKER = (make -> ready -> MAKER) .
```

```
USER = (ready -> use -> USER) .
```

```
|| MAKER_USER = (MAKER || USER) .
```

MAKER
synchronizes
with USER
when *ready*.

LTS? Traces? Number of states?

modeling interaction - handshake

A handshake is an action acknowledged by another:

```
MAKERv2 = (make -> ready -> used -> MAKERv2) .
```

3 states

```
USERv2 = (ready -> use -> used -> USERv2) .
```

3 states

```
|| MAKER_USERv2 = (MAKERv2 || USERv2) .
```

3 x 3
states?

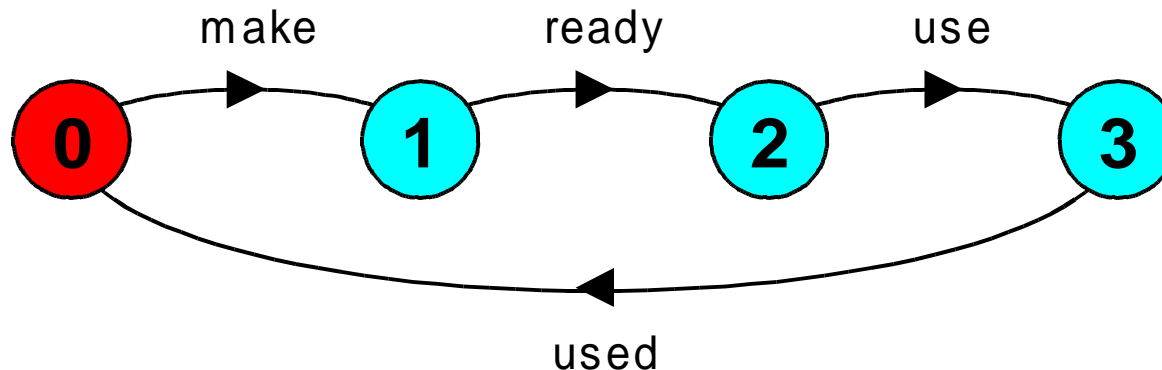

4 states

Interaction
constrains
the overall
behaviour.

modeling interaction - multiple processes

Multi-party synchronization:

```
MAKE_A    = (makeA->ready->used->MAKE_A) .  
MAKE_B    = (makeB->ready->used->MAKE_B) .  
ASSEMBLE  = (ready->assemble->used->ASSEMBLE) .  
|| FACTORY = (MAKE_A || MAKE_B || ASSEMBLE) .
```

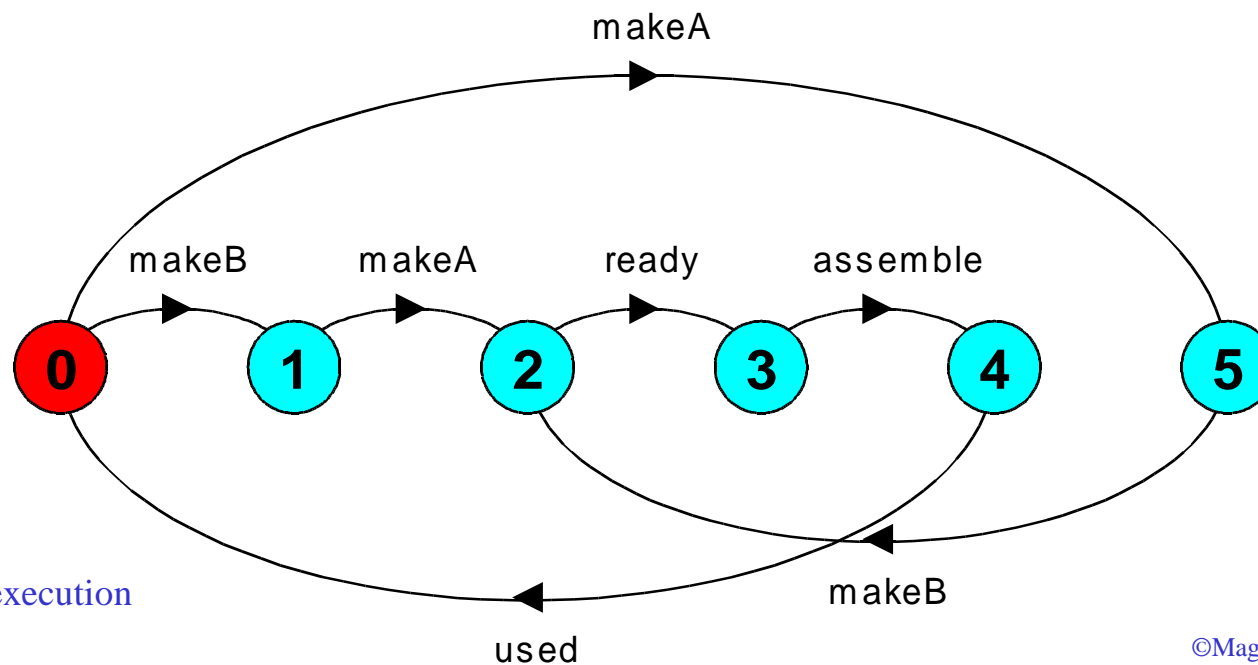

Concurrency: concurrent execution

10

©Magee/Kramer

composite processes

A composite process is a parallel composition of primitive processes. These composite processes can be used in the definition of further compositions.

```
|| MAKERS = (MAKE_A || MAKE_B) .
```

```
|| FACTORY = (MAKERS || ASSEMBLE) .
```

Substituting the definition for **MAKERS** in **FACTORY** and applying the **commutative** and **associative** laws for parallel composition results in the original definition for **FACTORY** in terms of primitive processes.

```
|| FACTORY = (MAKE_A || MAKE_B || ASSEMBLE) .
```

process labeling

$a:P$ prefixes each action label in the alphabet of P with a .

Two **instances** of a switch process:

$\text{SWITCH} = (\text{on} \rightarrow \text{off} \rightarrow \text{SWITCH}) .$

$|| \text{TWO_SWITCH} = (a:\text{SWITCH} || b:\text{SWITCH}) .$

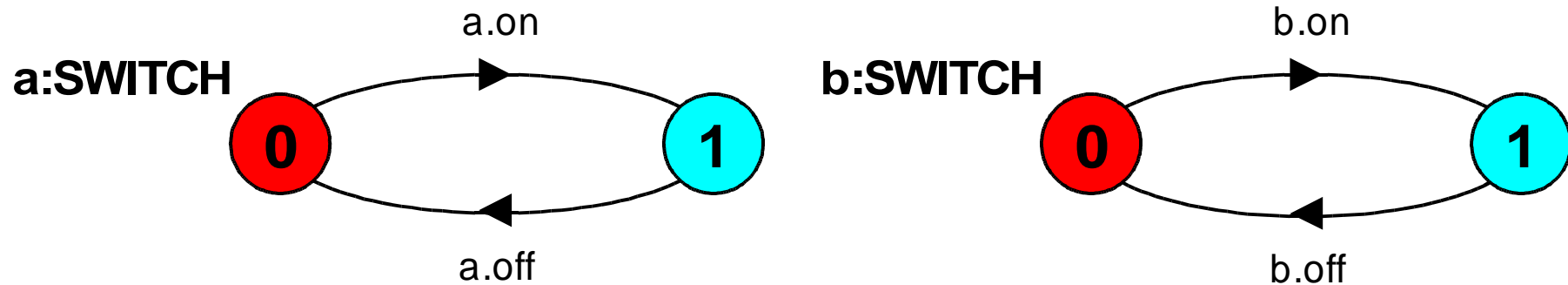

An array of **instances** of the switch process:

$|| \text{SWITCHES} (N=3) = (\text{forall} [i:1..N] s[i] : \text{SWITCH}) .$

$|| \text{SWITCHES} (N=3) = (s[i:1..N] : \text{SWITCH}) .$

Concurrency: concurrent execution

12

©Magee/Kramer

process labeling by a set of prefix labels

$\{a_1, \dots, a_x\}::P$ replaces every action label n in the alphabet of P with the labels $a_1.n, \dots, a_x.n$. Further, every transition ($n \rightarrow X$) in the definition of P is replaced with the transitions ($\{a_1.n, \dots, a_x.n\} \rightarrow X$).

Process prefixing is useful for modeling **shared** resources:

$\text{RESOURCE} = (\text{acquire} \rightarrow \text{release} \rightarrow \text{RESOURCE}) .$

$\text{USER} = (\text{acquire} \rightarrow \text{use} \rightarrow \text{release} \rightarrow \text{USER}) .$

$|| \text{RESOURCE_SHARE} = (\text{a} : \text{USER} \quad || \quad \text{b} : \text{USER} \\ || \quad \{ \text{a}, \text{b} \} :: \text{RESOURCE}) .$

process prefix labels for shared resources

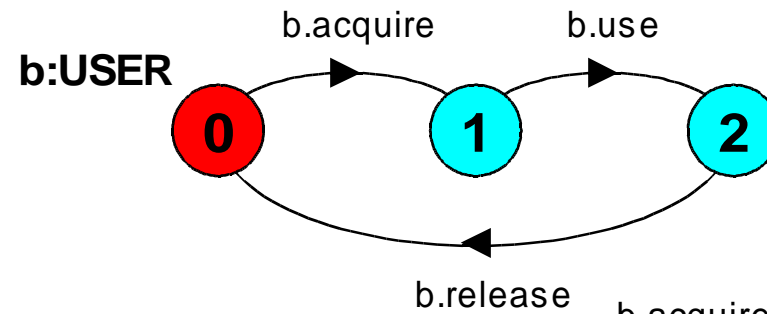
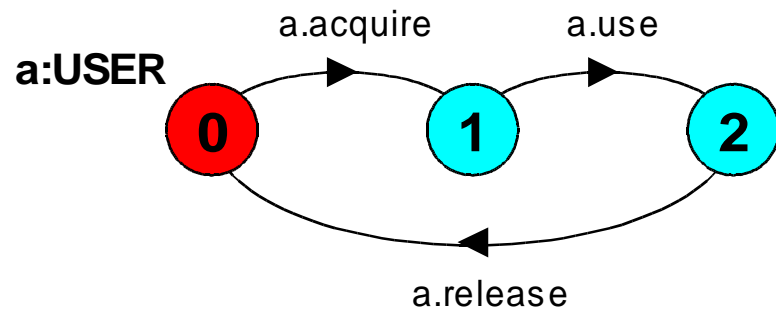

How does the model ensure that the user that acquires the resource is the one to release it?

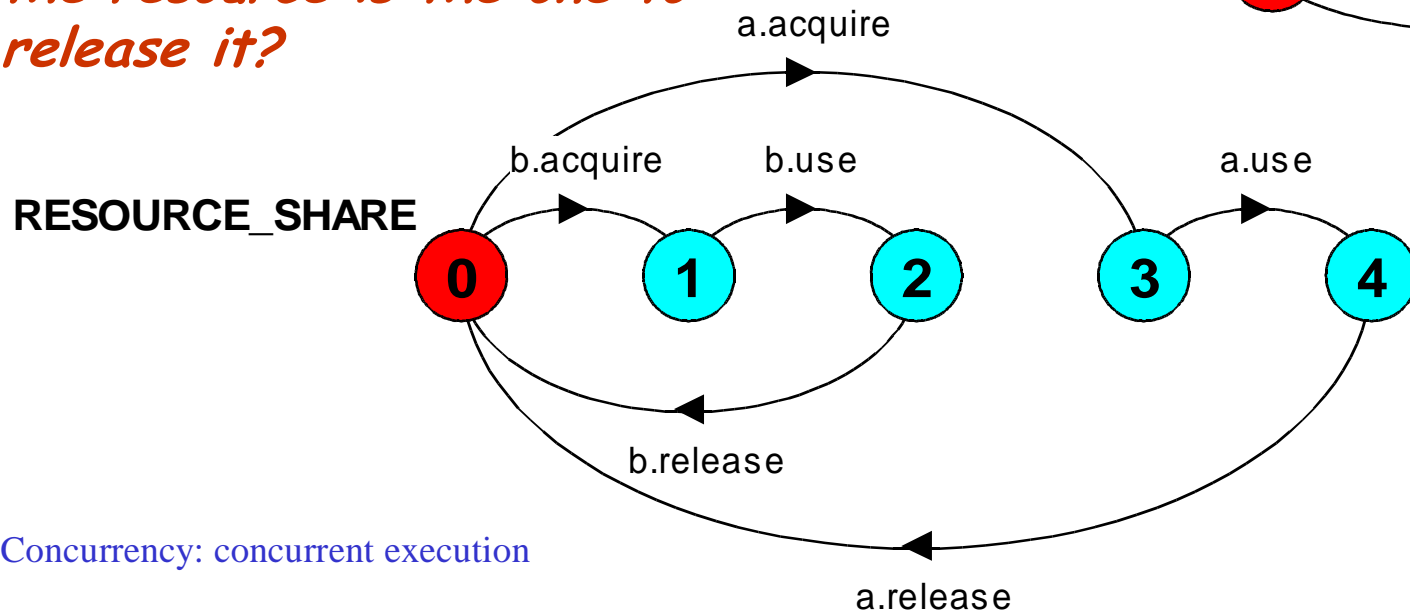
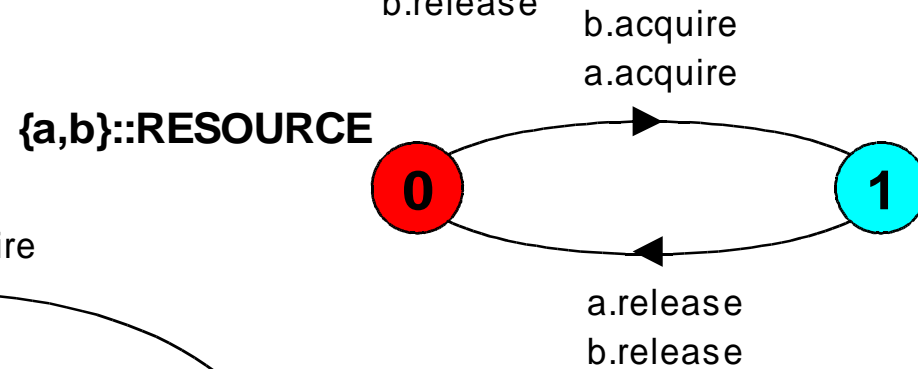

action relabeling

Relabeling functions are applied to processes to change the names of action labels. The general form of the relabeling function is:

/ {newlabel_1/oldlabel_1, ... newlabel_n/oldlabel_n}.

Relabeling to ensure that composed processes synchronize on particular actions.

CLIENT = (call->wait->continue->CLIENT) .

SERVER = (request->service->reply->SERVER) .

action relabeling

$|| \text{CLIENT_SERVER} = (\text{CLIENT} || \text{SERVER})$
 $/\{\text{call/request}, \text{reply/wait}\}.$

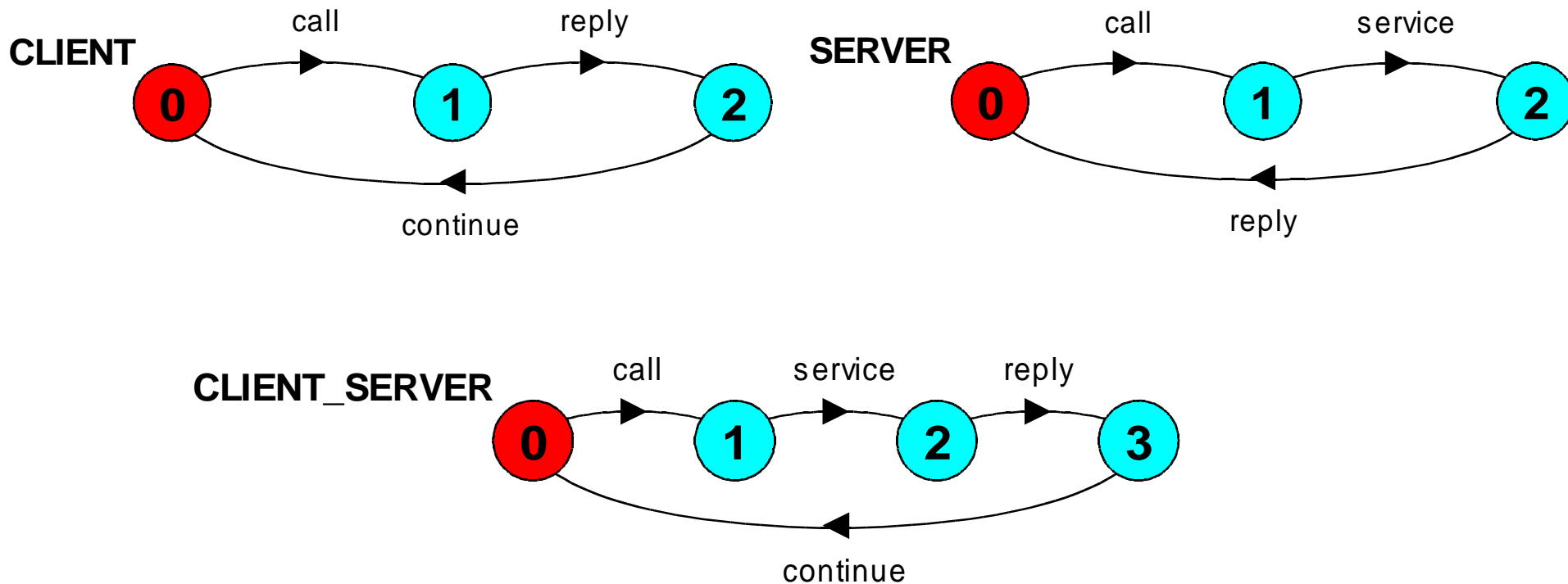

action relabeling - prefix labels

An alternative formulation of the client server system is described below using qualified or prefixed labels:

```
SERVERv2 = (accept.request
            ->service->accept.reply->SERVERv2) .
CLIENTv2 = (call.request
            ->call.reply->continue->CLIENTv2) .

|| CLIENT_SERVERv2 = (CLIENTv2 || SERVERv2)
                    /{call/accept} .
```

action **hiding** - abstraction to reduce complexity

When applied to a process P , the hiding operator $\{a1..ax\}$ removes the action names $a1..ax$ from the alphabet of P and makes these concealed actions "silent". These silent actions are labeled **tau**. Silent actions in different processes are not shared.

Sometimes it is more convenient to specify the set of labels to be **exposed**....

When applied to a process P , the interface operator $@\{a1..ax\}$ hides all actions in the alphabet of P not labeled in the set $a1..ax$.

action hiding

The following definitions are equivalent:

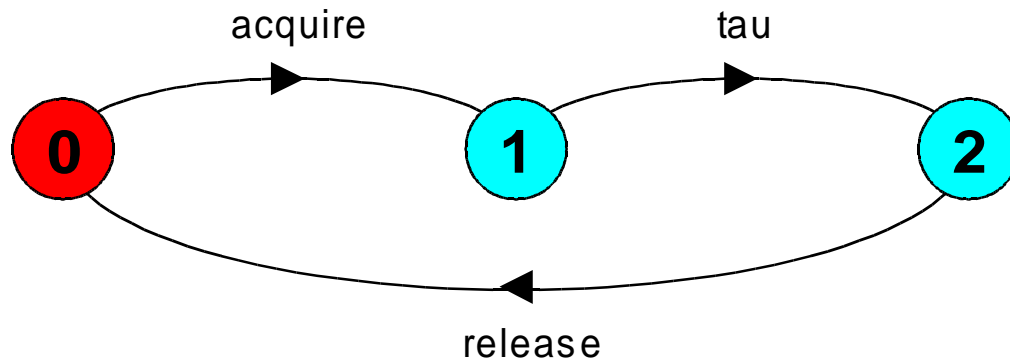
$$\text{USER} = (\text{acquire} \rightarrow \text{use} \rightarrow \text{release} \rightarrow \text{USER}) \setminus \{\text{use}\}.$$
$$\text{USER} = (\text{acquire} \rightarrow \text{use} \rightarrow \text{release} \rightarrow \text{USER}) @ \{\text{acquire}, \text{release}\}.$$

Minimization removes hidden tau actions to produce an LTS with equivalent observable behavior.

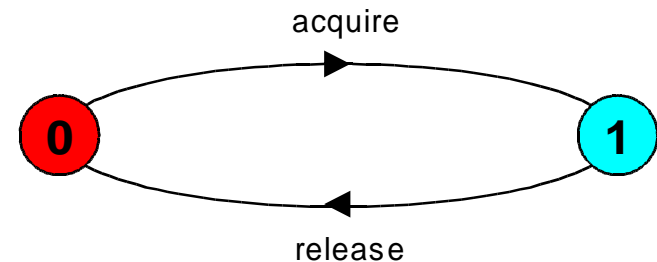

structure diagrams

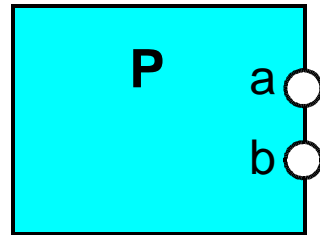

Process P with alphabet {a,b}.

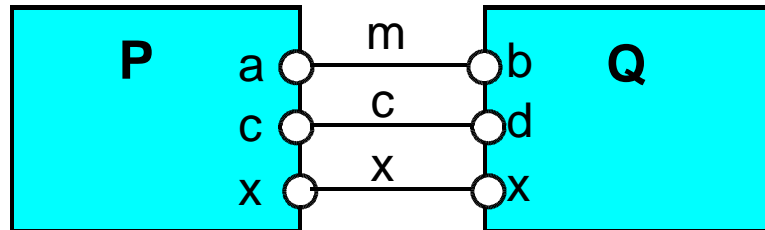

Parallel Composition
 $(P || Q) / \{m/a, m/b, c/d\}$

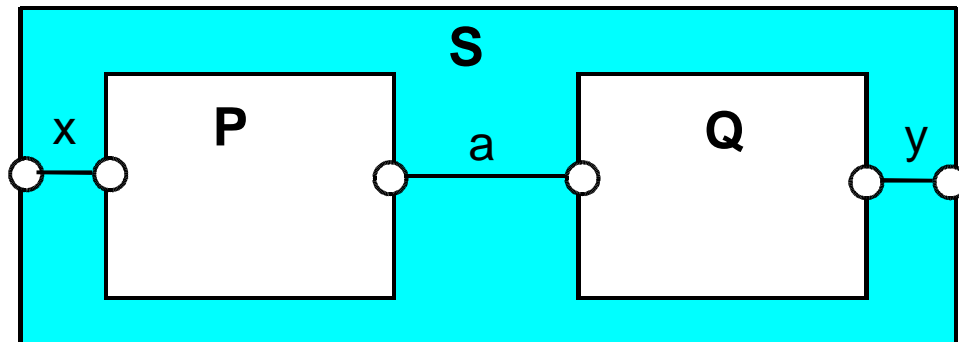

Composite process
 $||S = (P || Q) @ \{x,y\}$

Concurrency: concurrent execution

structure diagrams

We use structure diagrams to capture the structure of a model expressed by the static combinators:
parallel composition, relabeling and hiding.

```
range T = 0..3
```

```
BUFF = (in [i:T] -> out [i] -> BUFF) .
```

```
|| TWOBUFF = ?
```

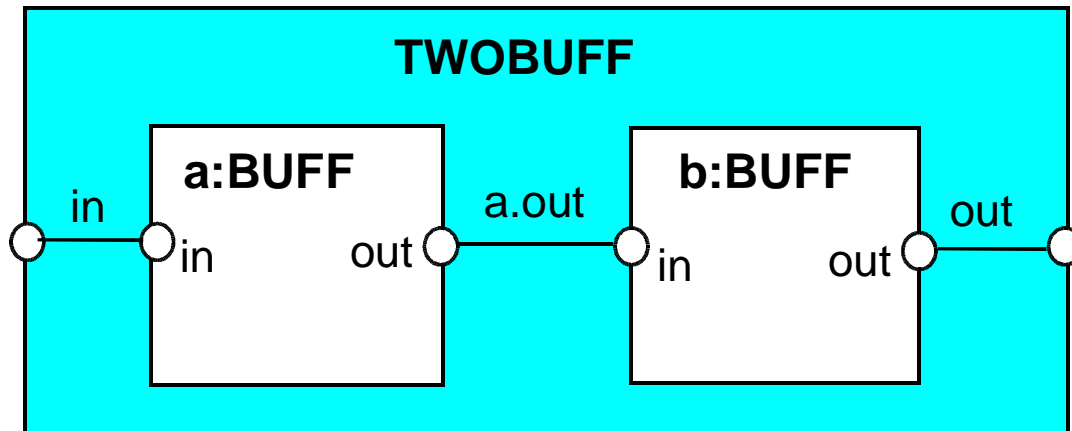

Concurrency: concurrent execution

structure diagrams

Structure diagram for CLIENT_SERVER ?

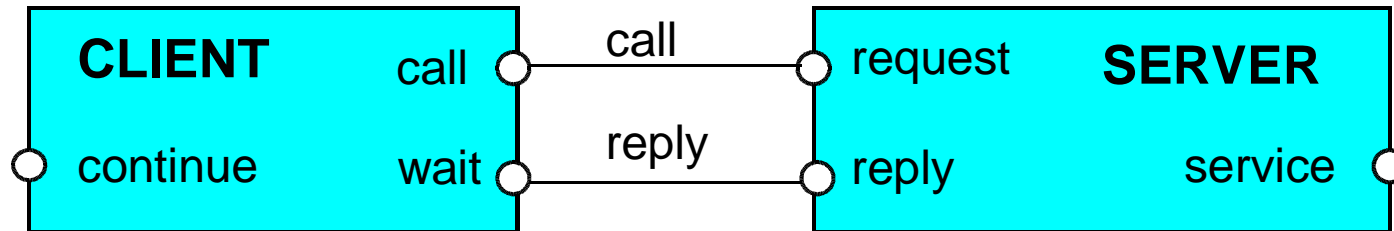

Structure diagram for CLIENT_SERVERv2 ?

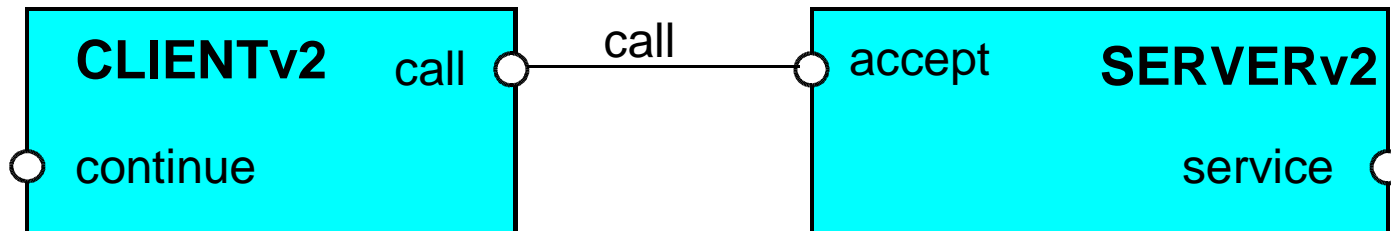

structure diagrams - resource sharing

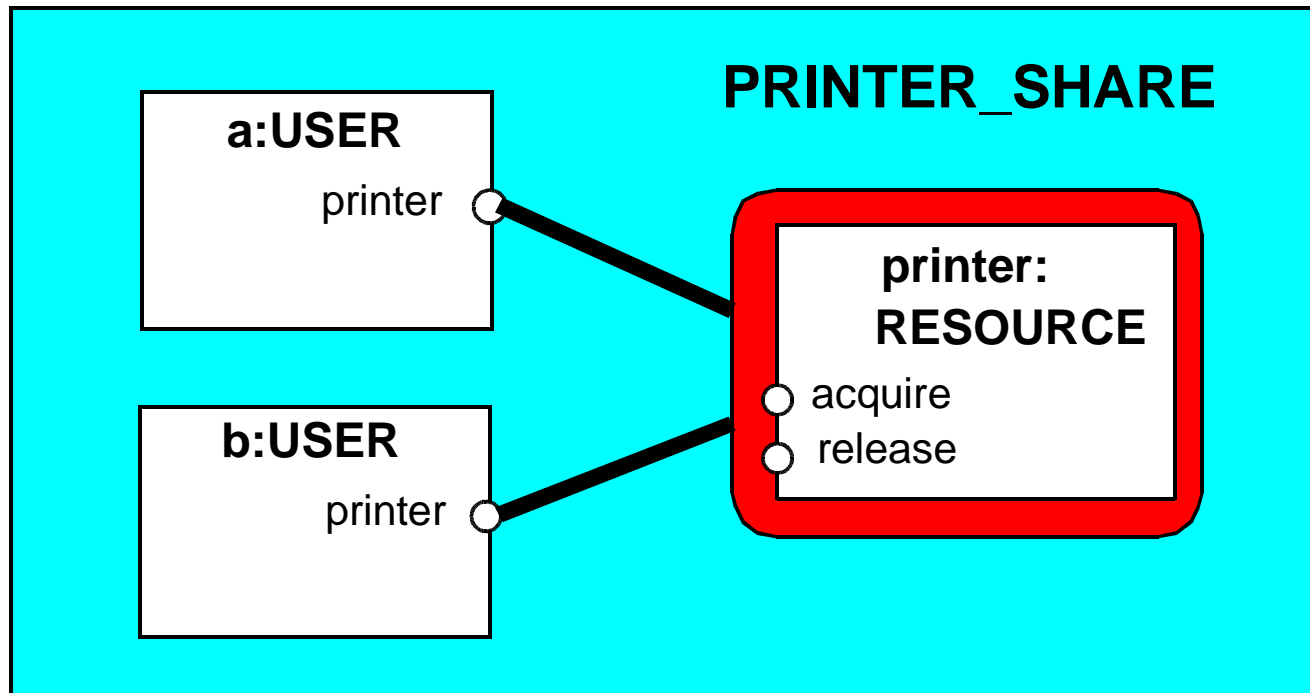

```
RESOURCE = (acquire->release->RESOURCE) .  
USER = (printer.acquire->use  
->printer.release->USER) .
```

```
|| PRINTER_SHARE  
= (a:USER || b:USER || {a,b}::printer:RESOURCE) .
```

Concurrency: concurrent execution

23

©Magee/Kramer

3.2 Multi-threaded Programs in Java

Concurrency in Java occurs when more than one thread is alive. ThreadDemo has two threads which rotate displays.

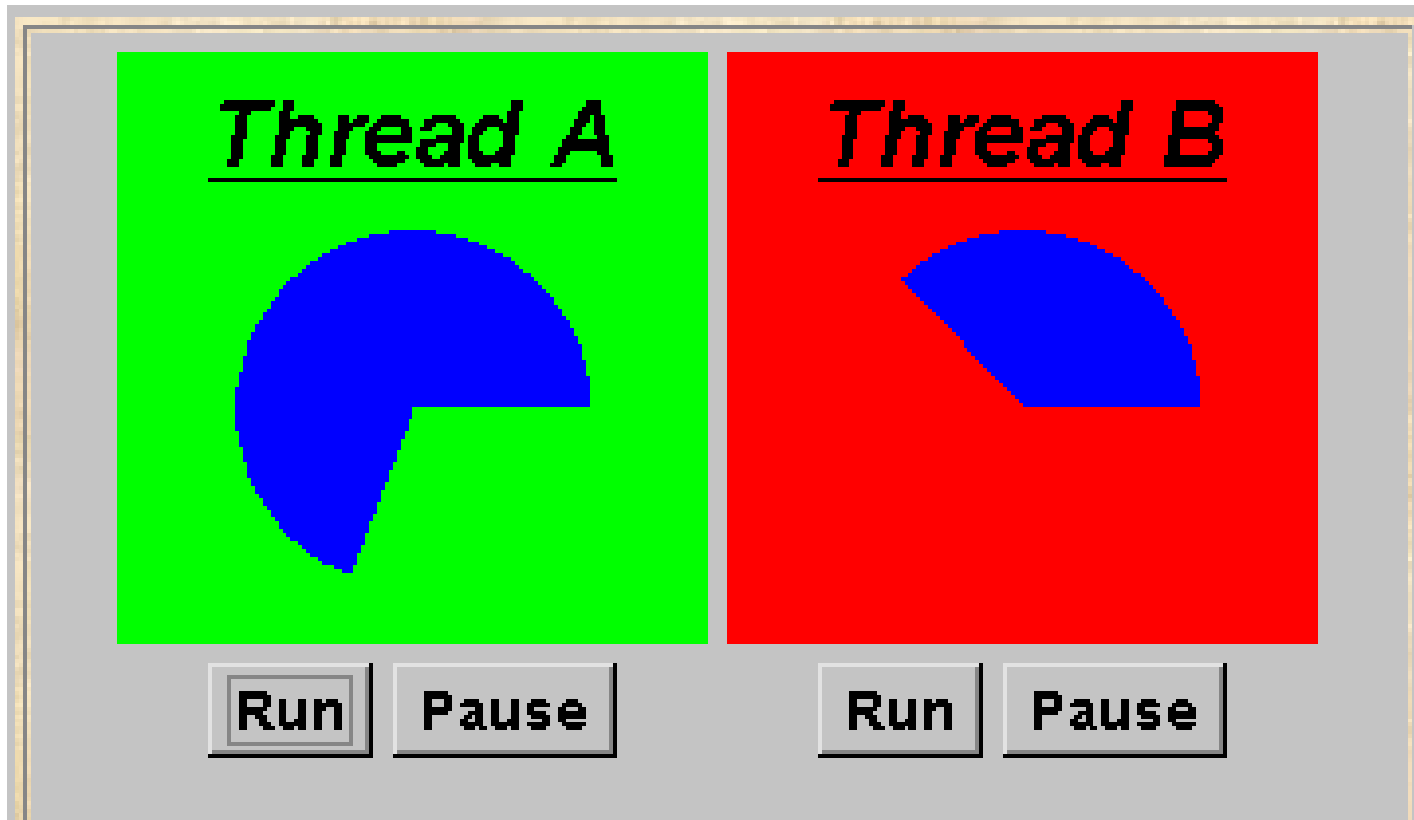

Concurrency: concurrent execution

ThreadDemo model

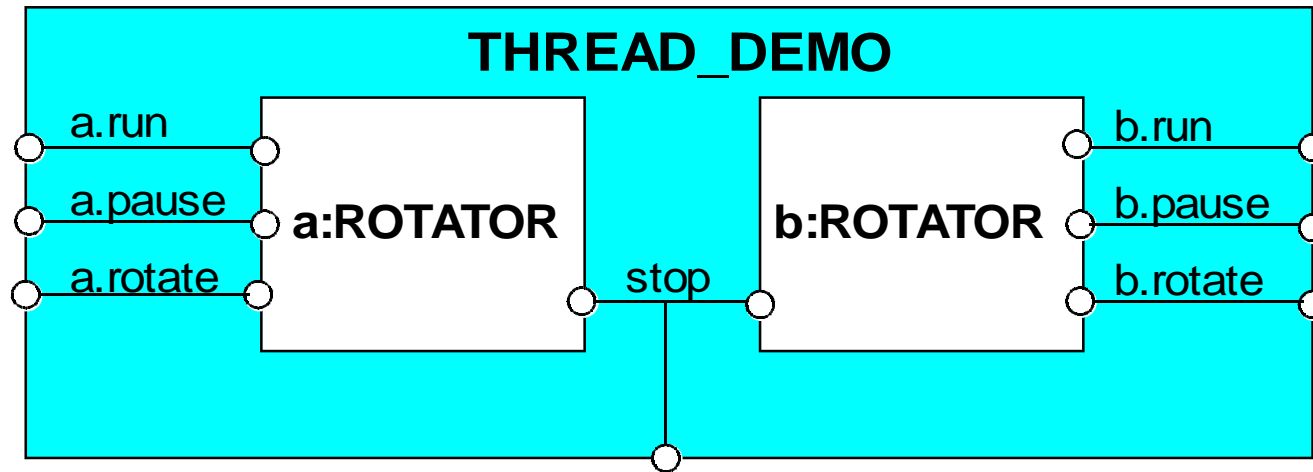

```
ROTATOR = PAUSED,  
PAUSED  = (run->RUN | pause->PAUSED  
           | interrupt->STOP),  
RUN      = (pause->PAUSED | {run, rotate}->RUN  
           | interrupt->STOP).
```

```
|| THREAD_DEMO = (a:ROTATOR || b:ROTATOR)  
/ {stop / {a, b}.interrupt}.
```

*Interpret
run,
pause,
interrupt
as inputs,
rotate as
an output.*

ThreadDemo implementation in Java - class diagram

ThreadDemo creates two **ThreadPanel** displays when initialized. **ThreadPanel** manages the display and control buttons, and delegates calls to `rotate()` to **DisplayThread**. **Rotator** implements the `Runnable` interface.

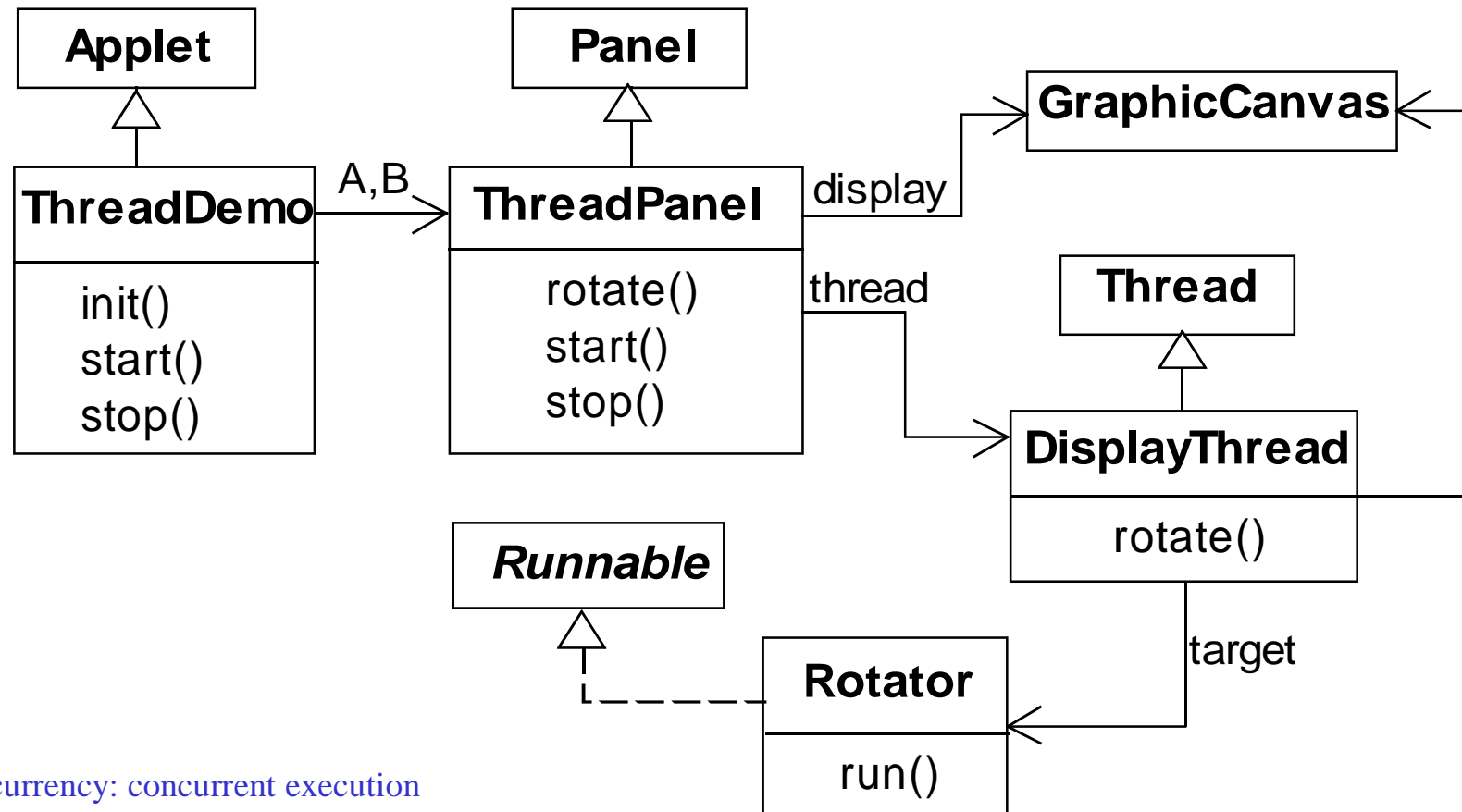

Rotator class

```
class Rotator implements Runnable {  
    public void run() {  
        try {  
            while(true) ThreadPanel.rotate();  
        } catch(InterruptedException e) {}  
    }  
}
```

`Rotator` implements the `Runnable` interface, calling `ThreadPanel.rotate()` to move the display.

`run()` finishes if an exception is raised by `Thread.interrupt()`.

ThreadPanel class

```
public class ThreadPanel extends Panel {  
  
    // construct display with title and segment color c  
    public ThreadPanel(String title, Color c) {...}  
  
    // rotate display of currently running thread 6 degrees  
    // return value not used in this example  
    public static boolean rotate()  
        throws InterruptedException {...}  
  
    // create a new thread with target r and start it running  
    public void start(Runnable r) {  
        thread = new DisplayThread(canvas, r, ...);  
        thread.start();  
    }  
  
    // stop the thread using Thread.interrupt()  
    public void stop() {thread.interrupt();}  
}
```

ThreadPanel
manages the display
and control buttons for
a thread.

Calls to `rotate()`
are delegated to
DisplayThread.

Threads are created by
the `start()` method,
and terminated by the
`stop()` method.

ThreadDemo class

```
public class ThreadDemo extends Applet {
    ThreadPanel A; ThreadPanel B;

    public void init() {
        A = new ThreadPanel("Thread A",Color.blue);
        B = new ThreadPanel("Thread B",Color.blue);
        add(A); add(B);
    }

    public void start() {
        A.start(new Rotator());
        B.start(new Rotator());
    }

    public void stop() {
        A.stop();
        B.stop();
    }
}
```

ThreadDemo creates two **ThreadPanel** displays when initialized and two threads when started.

ThreadPanel is used extensively in later demonstration programs.

Summary

◆ Concepts

- concurrent processes and process interaction

◆ Models

- **Asynchronous** (arbitrary speed) & **interleaving** (arbitrary order).
- **Parallel composition** as a finite state process with action interleaving.
- **Process interaction** by shared actions.
- **Process labeling** and action relabeling and hiding.
- **Structure diagrams**

◆ Practice

- **Multiple threads in Java.**

Concurrency: concurrent execution